

Poignée encastrable à visser, inox

11-172

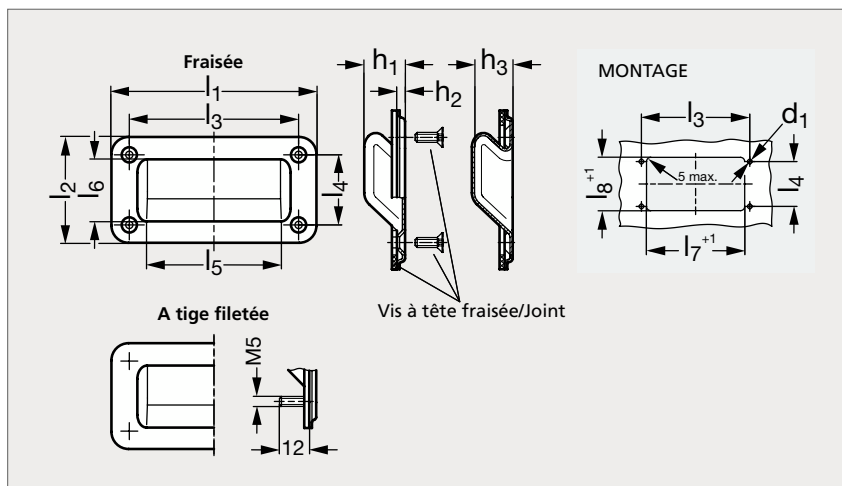

Fraisée, mate



Fraisée, polie



A tige filetée, mate



A tige filetée, polie

MATIÈRE

- Inox grenailé mat ou poli par électrolyse (AFNOR Z 6 CN 18-09, Werk 1.4301, AISI 304).
- Joint en NBR noir, collé.
- 4 vis à tête fraisée M5x16, en inox avec frein filet polyamide, fournies avec les versions fraisées avec joint.
- Tiges filetées en inox, soudées.

PRODUITS ASSOCIÉS



Vis tête fraisée 31-153



Charnière plate 37-13



Verrou à ressort 19-67



Glissière charge moyenne 39-06

FRAISÉE

Sans joint		Avec joint		l ₁	l ₂	l ₃	l ₄	l ₅	l ₆	l ₇	l ₈	h ₁	h ₂	h ₃	À TIGE FILETÉE			
Mate	Polie	Mate	Polie												Mate	Polie		
11-1721-155	11-1722-155	11-1723-155	11-1724-155	155	80	128	53	109	42	115	60	20	3,5	19,2	11-1725-155	11-1726-155	11-1727-155	11-1728-155

Référence

11-1721-155

Exemple
de commande