

Anneau de levage articulé à tige filetée

18-121

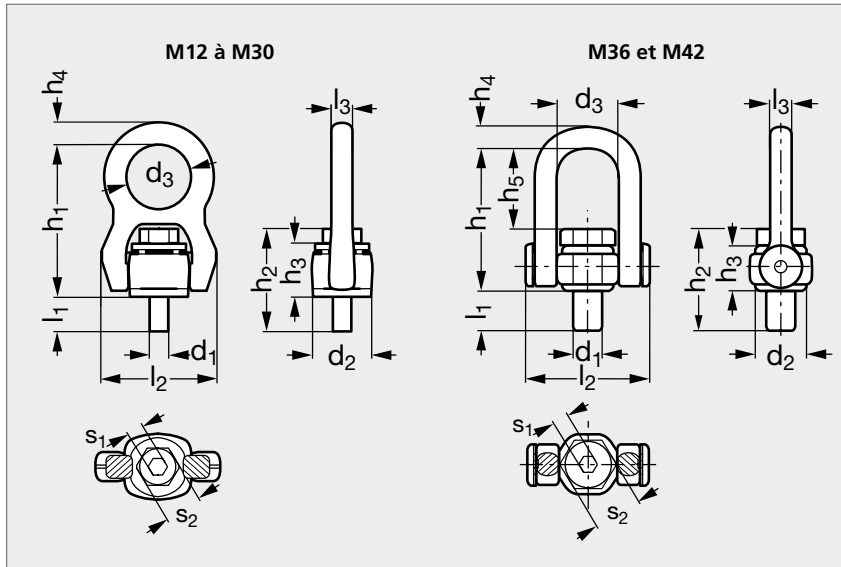

M36 et M42

M36 et M42

MATIÈRE

- Acier haute résistance Grade 120.
- Anneau, écrou et vis 100 % testés anti-fissures.

UTILISATION

- Ressort avec mécanisme unique garantissant une orientation automatique dans la direction de la traction.
- Puce RFID intégrée à l'anneau.
- Marquage sur le produit : Diamètre, CMU.
- Les capacités de charge doivent être réduites selon la température d'emploi.
- Coefficient de sécurité 4.

PRODUITS ASSOCIÉS

Plaque d'identification
18-98Adaptateur de filetage
18-20Anneau articulé
18-09Anneau articulé
18-119

Filetage métrique	d ₁	d ₁ UNC	d ₂	d ₃	h ₁	h ₂	h ₂ UNC	h ₃	h ₄	h ₅	l ₁	l ₁ UNC	l ₂	l ₃	s ₁	s ₁ UNC	s ₂	s ₂ UNC	CMU métrique	CMU UNC	Filetage UNC
18-1210-8	M 8		30	38	83	45,3		28	11		12		58	10,5	5		13		0,7		
18-1210-10	M10		30	38	83	50,4		28	11		16		58	10,5	6		17		1		
18-1210-12	M12	1/2"	30	38	83	54,5	54	28	11		19	18	58	10,5	8	5/16"	19	3/4"	1,35	1,35	18-1210-1/2
18-1210-16	M16	5/8"	40	50	107	68	68	36	14		22	22	76	14	10	3/8"	24	15/16"	2,5	2,5	18-1210-5/8
18-1210-20	M20	3/4"	45	50	118	82	80,5	43,5	17		26,5	25,5	89	17	12	1/2"	30	1 1/8"	4	4	18-1210-3/4
18-1210-24	M24	1"	60	66	154	104	106,5	55	23		34	36	121	23	14	9/16"	36	1 1/2"	6,3	6,3	18-1210-1
18-1210-30	M30	1 1/4"	75	75	183	128,7	134,5	68,5	29		41,5	46,5	148	27	17	5/8"	46	1 7/8"	8	8	18-1210-1 1/4
18-1210-36	M36	1 1/2"	70	82	189	128	131	60	32	106	45	48	168	32	22	7/8"	55	2 1/4"	12,5	14	18-1210-1 1/2
18-1210-42	M42	1 3/4"	70	82	189	136	141	60	32	104	53	56	168	32	24	1"	65	2 5/8"	16	16	18-1210-1 3/4

Exemple
de commande

Référence

18-1210-20