

# Loqueteau 2 billes zamac

19-115

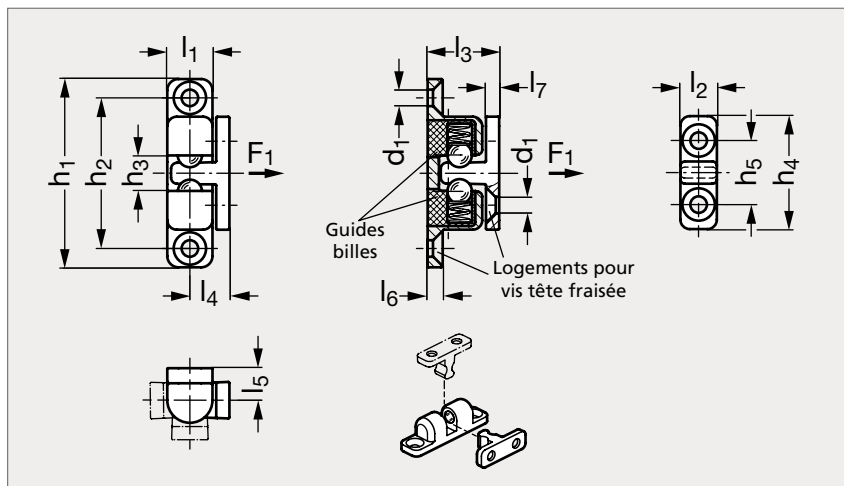

Noir, montage en face



Noir, montage latéral

## MATIÈRE

- Corps en zamac pelliculé noir ou gris argenté.
- Billes en inox A2.
- Ressorts en inox (AFNOR Z 12 CN 18-09, Werk 1.4310, AISI 301).
- Guides billes en plastique.

## PRODUITS ASSOCIÉS

Poignée technopolymère  
11-56  
Page 130Poignée mince aluminium  
11-48  
Page 118Charnière à friction,  
zamac 37-06  
Page 731Charnière plate  
technopolymère 37-13  
Page 751

## NOIR

Ressort normal	Ressort puissant	$h_1$	$h_2$	$h_3$	$h_4$	$h_5$	$d_1$	$l_1$	$l_2$	$l_3$	$l_4$	$l_5$	$l_6$	$l_7$	$F_1$ standard (N)	$F_1$ puissant (N)	Ressort normal	Ressort puissant
19-1151-38	19-1152-38	38	30	4,3	21	12	M3	8	7	15	7,5	7,5	4	2,5	25	35	19-1153-38	19-1154-38
19-1151-50	19-1152-50	50	40	6,5	30	17	M4	12	10	20	10,5	9,5	5	3,5	30	55	19-1153-50	19-1154-50
19-1151-68	19-1152-68	68	55	9,5	32,5	20	M4	14,5	11	23	12	11	5	3,5	50	70	19-1153-68	19-1154-68
19-1151-80	19-1152-80	80	65	11	40	25	M5	16,5	13	27	14	13	6	4	95	125	19-1153-80	19-1154-80

## GRIS

Exemple  
de commande

Référence

19-1151-38