

# Loquet à compression avec poignée étrier

19-121

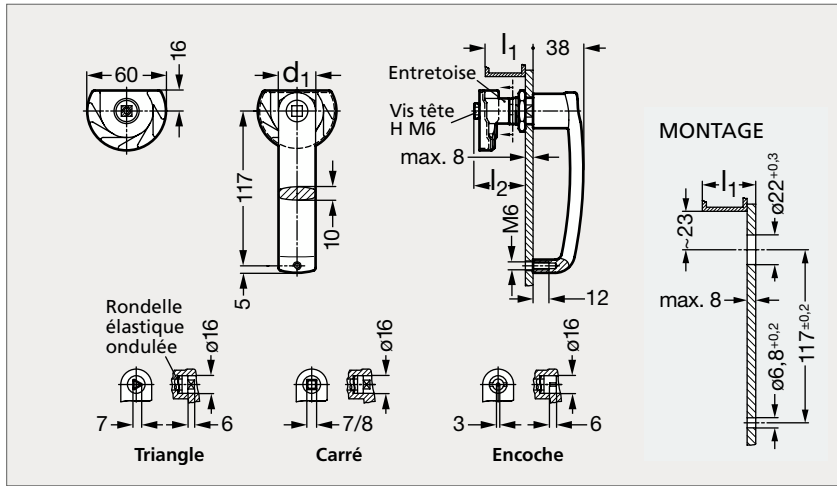

## MATIÈRE

- Poignée étrier en zamac pelliculé noir (RAL 9005) ou argenté (RAL 9006).
- Loquet à compression en acier zingué, passivé bleu avec entretoise en aluminium.

## UTILISATION

- Se référer à notre site internet pour consulter l'ensemble des informations.

## PRODUIT ASSOCIÉ



Clé pour loquets 19-102

## NOIR

NOIR				ARGENTÉ							
Triangle 7 mm	Carré 7 mm	Carré 8 mm	Encoche	d <sub>1</sub>	l <sub>1</sub> min.	l <sub>1</sub> max.	l <sub>2</sub>	Triangle 7 mm	Carré 7 mm	Carré 8 mm	Encoche
19-1210-28	19-1211-28	19-1212-28	19-1214-28	28	17	25	28	19-1215-28	19-1216-28	19-1217-28	19-1219-28
19-1210-28	19-1211-28	19-1212-28	19-1214-28	28	22	30	33	19-1215-28	19-1216-28	19-1217-28	19-1219-28
19-1210-28	19-1211-28	19-1212-28	19-1214-28	28	27	35	38	19-1215-28	19-1216-28	19-1217-28	19-1219-28
19-1210-28	19-1211-28	19-1212-28	19-1214-28	28	32	40	43	19-1215-28	19-1216-28	19-1217-28	19-1219-28
19-1210-28	19-1211-28	19-1212-28	19-1214-28	28	37	45	48	19-1215-28	19-1216-28	19-1217-28	19-1219-28
19-1210-28	19-1211-28	19-1212-28	19-1214-28	28	42	50	53	19-1215-28	19-1216-28	19-1217-28	19-1219-28
19-1210-28	19-1211-28	19-1212-28	19-1214-28	28	47	55	58	19-1215-28	19-1216-28	19-1217-28	19-1219-28
19-1210-28	19-1211-28	19-1212-28	19-1214-28	28	52	60	63	19-1215-28	19-1216-28	19-1217-28	19-1219-28
19-1210-28	19-1211-28	19-1212-28	19-1214-28	28	57	65	68	19-1215-28	19-1216-28	19-1217-28	19-1219-28

Exemple  
de commandeRéférence - l<sub>1</sub> (max)

19-1210-28-25

composants.emile-maurin.fr

**EMILE MAURIN**  
 ELEMENTS STANDARD MECANIQUE