

Ecrou rallongé

23-24

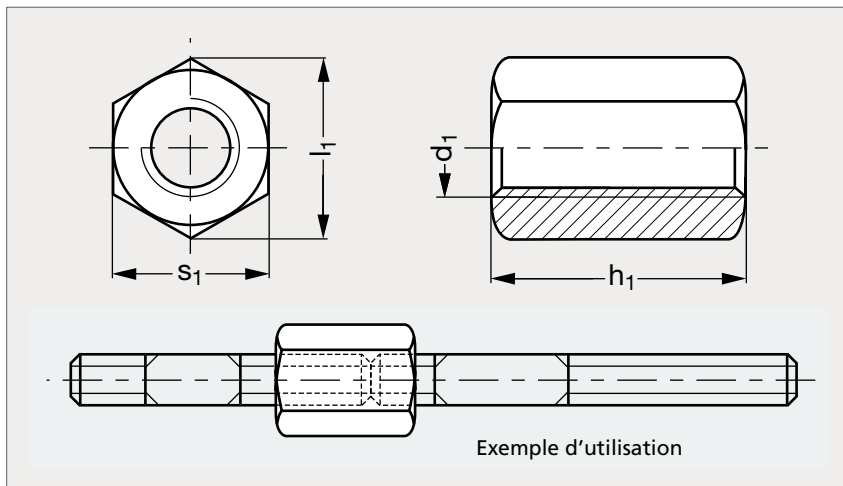

Acier



Inox

MATIÈRE

- Acier traité classe 10 ou inox A4.
- Norme DIN 6334.

* Cote s_1 , entre parenthèses valable pour l'inox.

PRODUITS ASSOCIÉS

Goujon DIN 6379 23-60
Page 1304-1305

Rondelle plate DIN 6340
23-42
Page 1297

Tasseau DIN 508 23-02
Page 1276

Tasseau série longue 23-03
Page 1277

Acier	d_1	h_1	l_1	s_1	Inox
23-240-6	M 6	18	11,5	10	23-245-6
23-240-8	M 8	24	15	13	23-245-8
23-240-10	M10	30	18,4	16(17)*	23-245-10
23-240-12	M12	36	20,7	18(19)*	23-245-12
23-240-14	M14	42	24,2	21	
23-240-16	M16	48	27,7	24	23-245-16
23-240-18	M18	54	31,2	27	
23-240-20	M20	60	34,6	30	23-245-20

Acier	d_1	h_1	l_1	s_1
23-240-22	M22	66	39,2	34
23-240-24	M24	72	41,5	36
23-240-27	M27	81	47,3	41
23-240-30	M30	90	53,1	46
23-240-36	M36	108	63,5	55
23-240-42	M42	126	75	65
23-240-48	M48	144	86,5	75

Exemple
de commande

Référence

23-240-6