

Accouplement à compensation angulaire

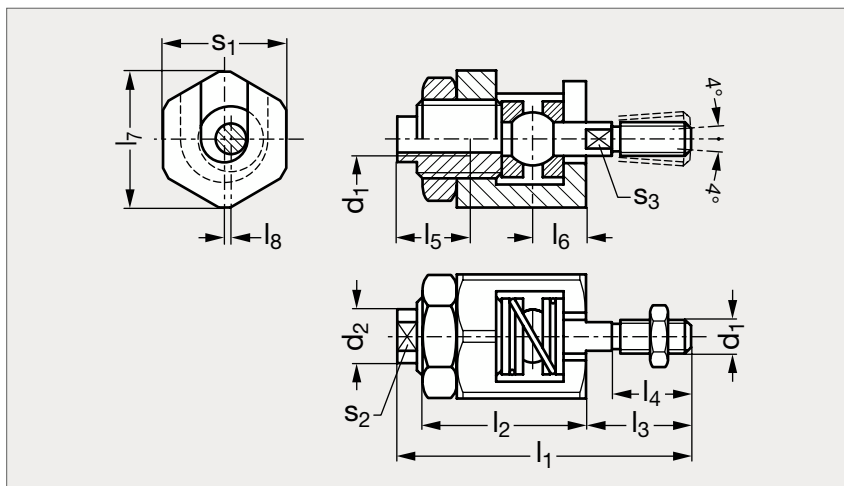

MATIÈRE

- Acier traité phosphaté.

F_1 (N) = force de traction et de pression admissible maximum.

PRODUITS ASSOCIÉS



Accouplement à
compression radiale 31-80
Page 1545



Accouplement à embase
31-81
Page 1546

	l_1	l_2	l_3	l_4	l_5 min.	l_6	l_7	l_8 max.	d_1	d_2	s_1	s_2	s_3	F_1 max. (N)	
31-821-52	52	29	18,5	14	13	9,5	24,5	0,6	M 6	9,5	22	8	5	2500	
31-821-63	63	33	23,5	18	16	11,5	30	0,7	M 8	15	27	13	7	4500	
31-821-81	81	43	30,5	22	24	16	44	0,7	M10	M10x1,25	21	41	18	12	6500
31-821-85	85	43	34,5	26	24	16	44	0,8	M12	M12x1,25	21	41	18	12	10000
31-821-121	121	62	45	34	34	26	60	1	M16	M16x1,5	32	55	27	18	18000
31-821-129	129	62	53	42	34	26	60	1	M20	M20x1,5	32	55	27	18	30000

Exemple
de commande

Référence - d_1

31-821-52-6

SÉRIE 31