

Doigt d'indexage tout inox

32-05

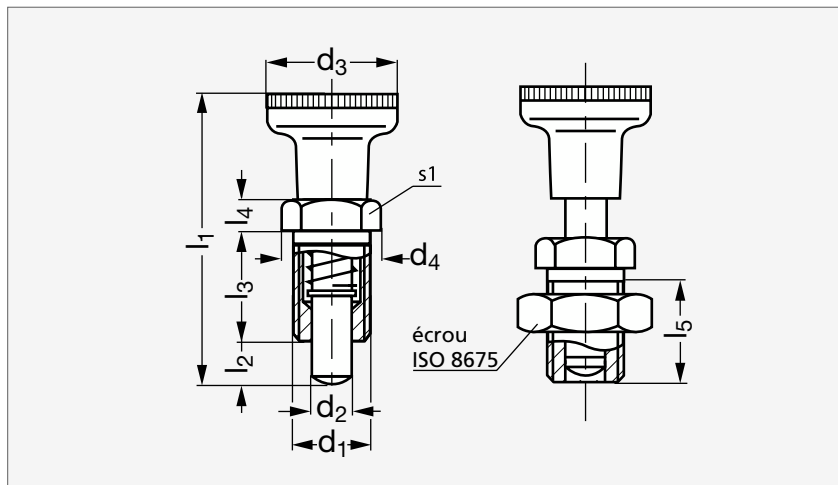

MATIÈRE

- Corps, goupille de centrage et bouton en inox (AFNOR Z 8 CNF 18-09, Werk 1.4305, AISI 303).
- Goupille de centrage traitée, rectifiée.

PRODUITS ASSOCIÉS

Entretoise 32-18
Page 535Douille de positionnement
32-39
Page 538

Sans écrou	d ₁	d ₂ ^{-0,02 -0,04}	d ₃	d ₄	l ₁	l ₂ min.	l ₃	l ₄	l ₅ min.	s ₁	Élasticité (N)		Avec écrou
											Début	Fin	
32-054-10	M10x1,00	5	21	13,8	45	5	17	5	15	12	6	15	32-059-10
32-054-12	M12x1,50	6	25	16,2	54,5	6	20	6	17	14	8	21	32-059-12
32-054-16	M16x1,50	8	31	21,9	69	8	26	8	23	19	9	26	32-059-16
32-054-20	M20x1,50	10	31	25,4	80	10	33	10	30	22	17	40	32-059-20

Référence

32-054-10

Exemple
de commande