

Broche de centrage magnétique, inox

32-151

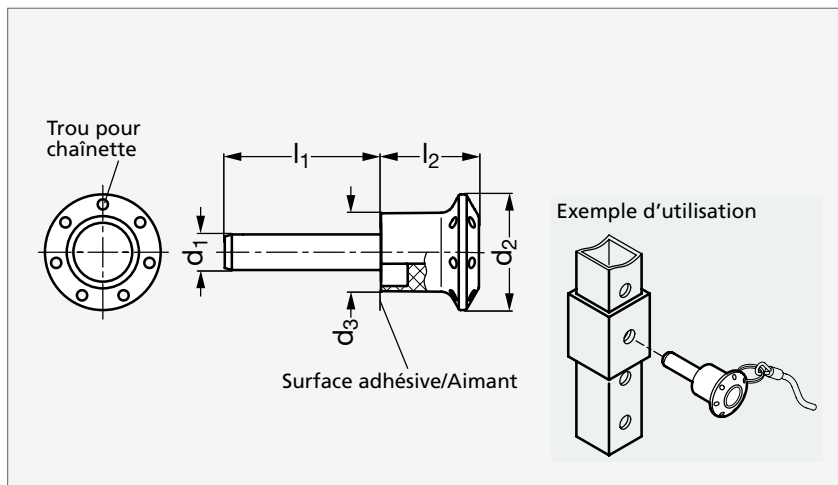

MATIÈRE

- Doigt en inox (AFNOR Z 8 CNF 18-09, Werk 1.4305, AISI 303).
- Tête en polyamide (PA) noir.
- Aimant en néodyme-fer-bore (NdFeB).

UTILISATION

- Température d'emploi jusqu'à + 80 °C.

PRODUITS ASSOCIÉS



Anneau 32-79
Page 560



Chaînette 32-80
Page 561



Câble 32-81
Page 562



Câble ressort 32-82
Page 563

	$d_{1-0,04}^{-0,08}$	d_2	d_3									l_1	l_2	Force de l'aimant (N)	Résistance au double cisaillement (kN)
32-1510-6	6	26	17,5	12	17	22	27	32	42	52	22	65	22		
32-1510-8	8	26	17,5	17	22	27	32	42	52	62	22	45	40		
32-1510-10	10	34	23	18	23	28	33	43	53	63	28,5	95	62		
32-1510-12	12	34	23	23	33	43	53	63	83		28,5	75	90		

Référence - l₁

32-1510-6-12

Exemple
de commande