

Support pour doigt d'indexage, acier ou inox

32-19

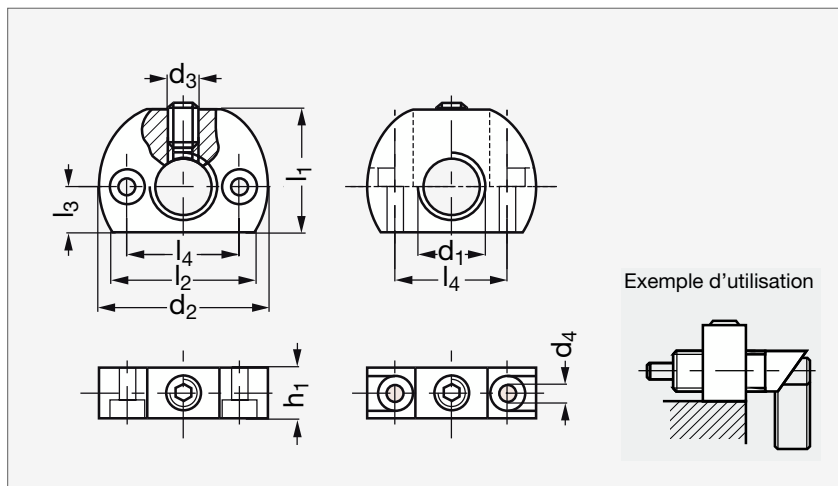

Axiale, acier



Axiale, inox



Radiale, acier

MATIÈRE

- Acier bruni ou inox (AFNOR Z 8 CNF 18-09, Werk 1.4305, AISI 303).
- Vis de pression avec embout laiton.

UTILISATION

- Le support aide au montage du doigt d'indexage et augmente ses domaines d'application.

PRODUITS ASSOCIÉS

Doigt d'indexage acier
ou inox 32-140
Page 490Doigt d'indexage acier
ou inox 32-141
Page 491Doigt d'indexage acier
ou inox avec blocage
32-142
Page 492Doigt d'indexage
à poignée 32-59
Page 504

ACIER

Fixation axiale	Fixation radiale	d ₁	d ₂	d ₃	d ₄	l ₁	l ₂	l ₃	l ₄ ^{±0,1}	h ₁	Fixation axiale	Fixation radiale
32-190-12	32-195-12	M12x1,5	32	M5	4,5	22	26,5	9	21	12	32-192-12	32-197-12
32-190-16	32-195-16	M16x1,5	46	M8	5,5	33	37	13	32	15	32-192-16	32-197-16
32-190-20	32-195-20	M20x1,5	46	M8	5,5	33	37	13	32	15	32-192-20	32-197-20

INOX

Exemple
de commande

Référence

32-190-12