

# Support pour doigt d'indexage

32-38

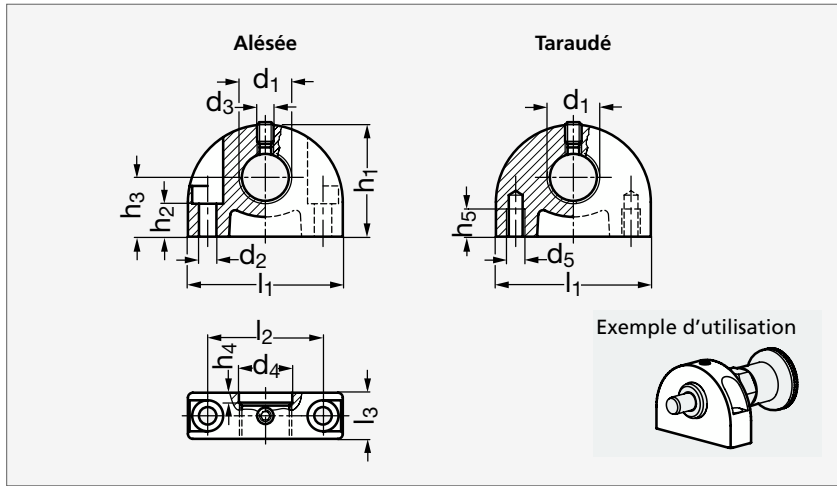

## MATIÈRE

- Zamac pelliculé noir mat.
- Vis de pression avec embout laiton.

## UTILISATION

- Le support aide au montage des doigts d'indexage et augmente ses domaines d'application.

## PRODUITS ASSOCIÉS



Douille de positionnement  
32-39  
Page 538



Doigt d'indexage  
32-06  
Page 460



Doigt d'indexage inox  
32-06  
Page 461



Doigt d'indexage  
32-11  
Page 486

## PAS FIN

Alésé	Taraudé	Fin	d <sub>1</sub>		d <sub>2</sub>	d <sub>3</sub>	d <sub>4</sub>	d <sub>5</sub>	l <sub>1</sub>	l <sub>2</sub>	l <sub>3</sub>	h <sub>1</sub>	h <sub>2</sub>	h <sub>3</sub>	h <sub>4</sub>	h <sub>5</sub> min.	PAS STANDARD	
			Standard														Alésé	Taraudé
32-380- 8	32-381- 8	M 8x1	M 8		4,3	M4	8,2	M5	35	25	12	26	6	14	2	10	32-382- 8	32-383- 8
32-380-10	32-381-10	M10x1	M10		4,3	M4	10,2	M5	35	25	12	26	6	14	2	10	32-382-10	32-383-10
32-380-12	32-381-12	M12x1,5	M12		4,3	M4	12,2	M5	35	25	12	26	6	14	3	12	32-382-12	32-383-12
32-380-16	32-381-16	M16x1,5	M16		5,3	M5	16,2	M6	47	35	14	34	10	18	3	12	32-382-16	32-383-16
32-380-20	32-381-20	M20x1,5			5,3	M5	20,2	M6	47	35	14	34	10	18	3	12		

Exemple  
de commande

Référence  
**32-380-8**