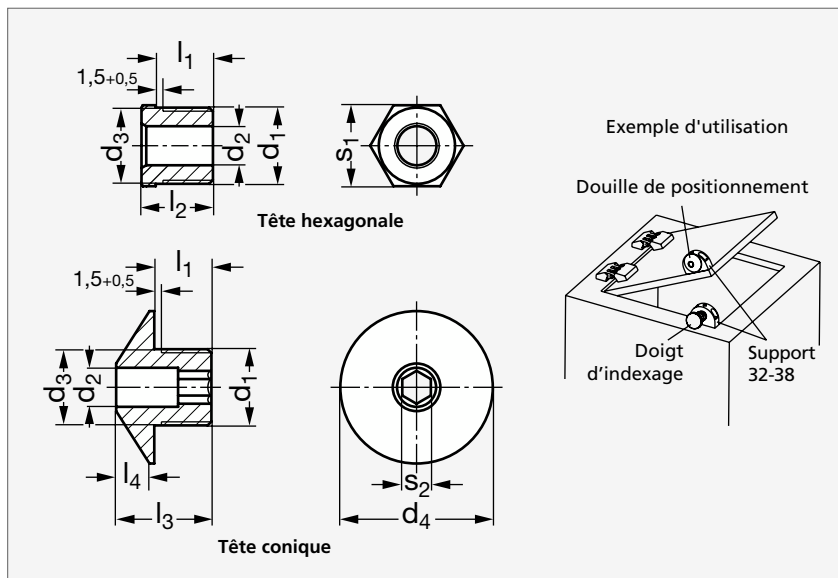

Douille de positionnement pour doigt d'indexage, à tête hexagonale ou conique, acier ou inox

32-39

Acier,
tête hexagonaleAcier,
tête coniqueInox,
tête hexagonaleInox,
tête conique

MATIÈRE

- Acier durci bruni ou inox (AFNOR Z 15 CN 16-02, Werk 1.4057, AISI 431) durci.

PRODUIT ASSOCIÉ

Support 32-38
Page 537

ACIER

Tête hexagonale	Tête conique	d ₁	d ₂ ^{+0,3 +0,2}	d ₃ ^{-0,05}	d ₄	l ₁	l ₂	l ₃	l ₄	l ₅	s ₁	s ₂	Tête hexagonale	Tête conique
32-390-12	32-391-12	M12x1,5	4	12	24	10	13	16	5	11	13	4	32-395-12	32-396-12
32-390-12	32-391-12	M12x1,5	5	12	24	10	13	16	5	11	13	4	32-395-12	32-396-12
32-390-12	32-391-12	M12x1,5	6	12	24	10	13	16	5	11	13	4	32-395-12	32-396-12
32-390-16	32-391-16	M16x1,5	8	16	32	12	15	20	7	13	17	6	32-395-16	32-396-16
32-390-16	32-391-16	M16x1,5	10	16	32	12	15	20	7	13	17	6	32-395-16	32-396-16
32-390-16	32-391-16	M16x1,5	12	16	32	12	15	20	7	13	17	6	32-395-16	32-396-16

INOX

Exemple
de commandeRéférence - d₂

32-390-12-4