

Pied acier ou inox, avec patte de fixation, taraudé

35-100

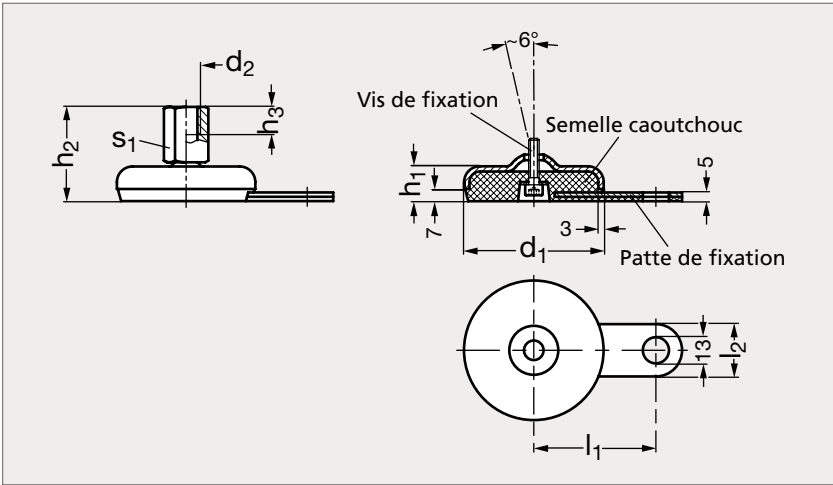

Acier



Inox

MATIÈRE

- Base et patte de fixation en acier zingué, passivé bleu ou en inox (AFNOR Z 6 CN 18-09, Werk 1.4301, AISI 304), mat.
- Insert taraudé inclinable en acier zingué, passivé bleu ou en inox (AFNOR Z 8 CNF 18-09, Werk 1.4305, AISI 303).
- Semelle en caoutchouc Perbunan (NBR) noir, 80 ± 5 shore A.

Pied acier ou inox, avec patte de fixation, taraudé

35-100

Acier	d ₁	d ₂	l ₁	l ₂	h ₁	h ₂	h ₃	s ₁	Charge statique acier (kN)	Charge statique inox (kN)	Inox
35-1001- 50	50	M 8	45	25	18	40	8	14	8	8	35-1005- 50
35-1001- 50	50	M10	45	25	18	43	10	14	13	13	35-1005- 50
35-1001- 50	50	M12	45	25	18	47	12	17	16	20	35-1005- 50
35-1001- 50	50	M16	45	25	18	52	16	22	16	28	35-1005- 50
35-1001- 60	60	M 8	50	25	19	41	8	14	8	8	35-1005- 60
35-1001- 60	60	M10	50	25	19	44	10	14	13	13	35-1005- 60
35-1001- 60	60	M12	50	25	19	48	12	17	16	20	35-1005- 60
35-1001- 60	60	M16	50	25	19	53	16	22	16	28	35-1005- 60
35-1001- 80	80	M 8	70	30	20	42	8	14	8	8	35-1005- 80
35-1001- 80	80	M10	70	30	20	45	10	14	12	13	35-1005- 80
35-1001- 80	80	M12	70	30	20	49	12	17	12	15	35-1005- 80
35-1001- 80	80	M16	70	30	20	54	16	22	12	19	35-1005- 80
35-1001- 80	80	M20	70	30	20	62	20	27	12	19	35-1005- 80
35-1001-100	100	M 8	80	30	21	43	8	14	8	8	35-1005-100
35-1001-100	100	M10	80	30	21	46	10	14	11	13	35-1005-100
35-1001-100	100	M12	80	30	21	50	12	17	11	17	35-1005-100
35-1001-100	100	M16	80	30	21	55	16	22	11	17	35-1005-100
35-1001-100	100	M20	80	30	21	63	20	27	11	17	35-1005-100

Exemple
de commandeRéférence - d₂
35-1001-50-8
composants.emile-maurin.fr
EMILE MAURIN
 ELEMENTS STANDARD MECANQUES