

Pied acier ou inox, taraudé, avec semelle en caoutchouc

35-27

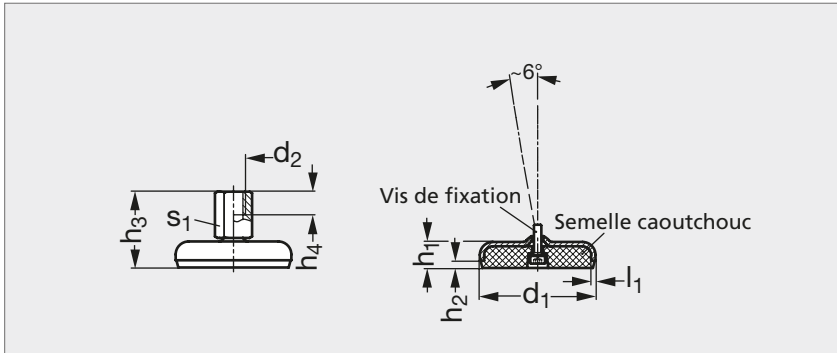

MATIÈRE

- Base en acier zingué, passivé bleu ou en acier pelliculé noir ou en inox (AFNOR Z 6 CN 18-09, Werk 1.4301, AISI 304), mat.
- Insert taraudé inclinable en acier zingué, passivé bleu ou en inox (AFNOR Z 8 CNF 18-09, Werk 1.4305, AISI 303).
- Semelle en caoutchouc Perbunan (NBR) noir ou Santoprène (TPE) blanc, 80 ± 5 shore A.

ACIER ZINGUE

ACIER PELLICULE NOIR

INOX

Noir		Blanc		Noir		Blanc		d ₁	d ₂	l ₁	h ₁	h ₂	h ₃	h ₄	s ₁	Charge statique acier (kN)		Charge statique inox (kN)		INOX		
																Noir	Blanc	Noir	Blanc	Noir	Blanc	
35-271- 50	35-271- 50	35-271- 50	35-271- 50	35-271- 50	35-271- 50	35-271- 50	35-271- 50	50	M 8	3	14,5	3,5	37	8	14	8	8	8	8	8	35-273- 50	35-273- 50
35-271- 50	35-271- 50	35-271- 50	35-271- 50	35-271- 50	35-271- 50	35-271- 50	35-271- 50	50	M 10	3	14,5	3,5	40	10	14	13	13	13	13	13	35-273- 50	35-273- 50
35-271- 50	35-271- 50	35-271- 50	35-271- 50	35-271- 50	35-271- 50	35-271- 50	35-271- 50	50	M 12	3	14,5	3,5	43	12	17	16	16	13	13	13	35-273- 50	35-273- 50
35-271- 50	35-271- 50	35-271- 50	35-271- 50	35-271- 50	35-271- 50	35-271- 50	35-271- 50	50	M 16	3	14,5	3,5	49	16	22	16	16	13	13	13	35-273- 50	35-273- 50
35-271- 60	35-271- 60	35-271- 60	35-271- 60	35-271- 60	35-271- 60	35-271- 60	35-271- 60	60	M 8	3	16	4	38	8	14	8	8	8	8	8	35-273- 60	35-273- 60
35-271- 60	35-271- 60	35-271- 60	35-271- 60	35-271- 60	35-271- 60	35-271- 60	35-271- 60	60	M 10	3	16	4	41	10	14	13	13	13	13	13	35-273- 60	35-273- 60
35-271- 60	35-271- 60	35-271- 60	35-271- 60	35-271- 60	35-271- 60	35-271- 60	35-271- 60	60	M 12	3	16	4	45	12	17	16	16	13	13	13	35-273- 60	35-273- 60
35-271- 60	35-271- 60	35-271- 60	35-271- 60	35-271- 60	35-271- 60	35-271- 60	35-271- 60	60	M 16	3	16	4	50	16	22	16	16	13	13	13	35-273- 60	35-273- 60
35-271- 80	35-271- 80	35-271- 80	35-271- 80	35-271- 80	35-271- 80	35-271- 80	35-271- 80	80	M 8	3	18	5	40	8	14	8	8	8	8	8	35-273- 80	35-273- 80
35-271- 80	35-271- 80	35-271- 80	35-271- 80	35-271- 80	35-271- 80	35-271- 80	35-271- 80	80	M 10	3	18	5	43	10	14	12	12	11	11	11	35-273- 80	35-273- 80
35-271- 80	35-271- 80	35-271- 80	35-271- 80	35-271- 80	35-271- 80	35-271- 80	35-271- 80	80	M 12	3	18	5	47	12	17	12	12	11	11	11	35-273- 80	35-273- 80
35-271- 80	35-271- 80	35-271- 80	35-271- 80	35-271- 80	35-271- 80	35-271- 80	35-271- 80	80	M 16	3	18	5	52	16	22	12	12	11	11	11	35-273- 80	35-273- 80
35-271- 80	35-271- 80	35-271- 80	35-271- 80	35-271- 80	35-271- 80	35-271- 80	35-271- 80	80	M 20	3	18	5	60	20	27	12	12	11	11	11	35-273- 80	35-273- 80
35-271-100	35-271-100	35-271-100	35-271-100	35-271-100	35-271-100	35-271-100	35-271-100	100	M 8	3	20	6	42	8	14	8	8	8	8	8	35-273-100	35-273-100
35-271-100	35-271-100	35-271-100	35-271-100	35-271-100	35-271-100	35-271-100	35-271-100	100	M 10	3	20	6	45	10	14	11	11	10	10	10	35-273-100	35-273-100
35-271-100	35-271-100	35-271-100	35-271-100	35-271-100	35-271-100	35-271-100	35-271-100	100	M 12	3	20	6	49	12	17	11	11	10	10	10	35-273-100	35-273-100
35-271-100	35-271-100	35-271-100	35-271-100	35-271-100	35-271-100	35-271-100	35-271-100	100	M 16	3	20	6	54	16	22	11	11	10	10	10	35-273-100	35-273-100
35-271-100	35-271-100	35-271-100	35-271-100	35-271-100	35-271-100	35-271-100	35-271-100	100	M 20	3	20	6	62	20	27	11	11	10	10	10	35-273-100	35-273-100
35-271-120	35-271-120	35-271-120	35-271-120	35-271-120	35-271-120	35-271-120	35-271-120	120	M 20	4	22	6	65	20	27	20	20	16	16	16	35-273-120	35-273-120

Exemple de commande

Référence - d₂
35-271-50-8