

Pied à rotule acier ou inox, taraudé

35-46

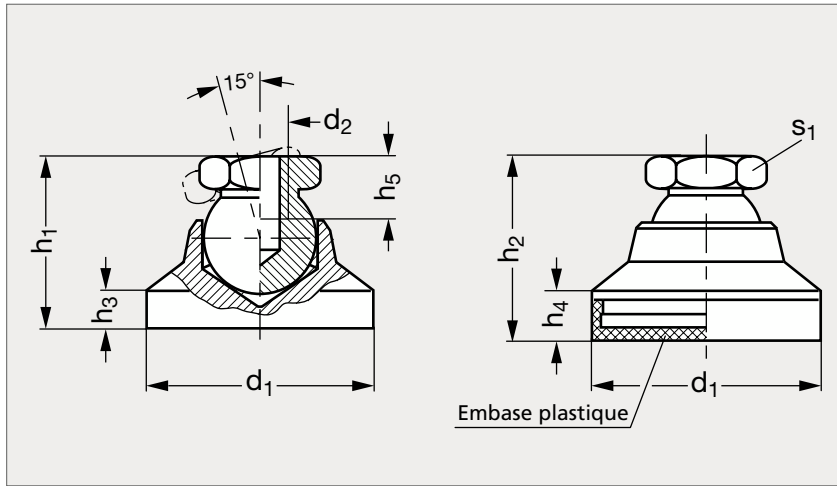

Acier, embase delrin



Acier, embase élastomère



Inox, embase delrin

MATIÈRE

- Acier zingué ou inox (AFNOR Z 8 CNF 18-09, Werk 1.4305, AISI 303).
- Embase en plastique delrin blanc ou élastomère noir 73 shore.

PRODUITS ASSOCIÉS

Insert taraudé 35-60
Page 1004Insert taraudé 35-61
Page 1006Insert taraudé 35-62
Page 1005Insert taraudé 35-63
Page 1007

ACIER

Sans embase plastique	Embase delrin	Embase élastomère	d ₁	d ₂	h ₁	h ₂	h ₃	h ₄	h ₅ min.	s ₁	Sans embase plastique	Embase delrin	Embase élastomère
35-461-25	35-462-25	35-463-25	25	M 6	19	20,5	4	5,5	9	12	35-465-25	35-466-25	35-467-25
35-461-25	35-462-25	35-463-25	25	M 8	19	20,5	4	5,5	9	12	35-465-25	35-466-25	35-467-25
35-461-32	35-462-32	35-463-32	32	M 8	23	24,5	5	6,5	9	12	35-465-32	35-466-32	35-467-32
35-461-32	35-462-32	35-463-32	32	M10	23	24,5	5	6,5	10,5	15	35-465-32	35-466-32	35-467-32
35-461-40	35-462-40	35-463-40	40	M10	26	27,5	6	7,5	10,5	15	35-465-40	35-466-40	35-467-40
35-461-40	35-462-40	35-463-40	40	M12	26	27,5	6	7,5	11,5	17	35-465-40	35-466-40	35-467-40
35-461-50	35-462-50	35-463-50	50	M10	28	29,5	7	8,5	10,5	15	35-465-50	35-466-50	35-467-50
35-461-50	35-462-50	35-463-50	50	M12	28	29,5	7	8,5	11,5	17	35-465-50	35-466-50	35-467-50
35-461-60	35-462-60	35-463-60	60	M12	36	37,5	8,5	10	11,5	17	35-465-60	35-466-60	35-467-60
35-461-60	35-462-60	35-463-60	60	M16	36	37,5	8,5	10	16	24	35-465-60	35-466-60	35-467-60

INOX

Exemple
de commandeRéférence - d₂

35-461-25-6