

Pied à rotule acier ou inox, à tige filetée

35-48

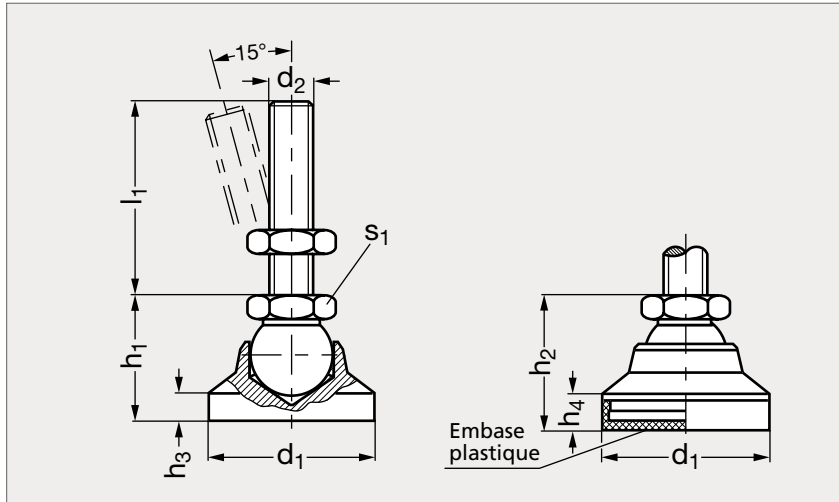

Acier, sans embase



Acier, embase delrin



Inox, sans embase



Inox, embase élastomère

MATIÈRE

- Acier zingué ou inox (AFNOR Z 8 CNF 18-09, Werk 1.4305, AISI 303).
- Embase en plastique delrin blanc ou élastomère noir 73 shore.

PRODUITS ASSOCIÉS

Insert taraudé 35-60
Page 1004Insert taraudé 35-61
Page 1006Insert taraudé 35-62
Page 1005Insert taraudé 35-63
Page 1007

Pied à rotule acier ou inox, à tige filetée

35-48

ACIER													INOX				
Sans embase	Embase delrin	Embase élastomère	d ₁	d ₂	l ₁			h ₁	h ₂	h ₃	h ₄	s ₁	Charge statique acier (kN)	Charge statique inox (kN)	Sans embase	Embase delrin	Embase élastomère
35-481-25	35-482-25	35-483-25	25	M 6	40	50	63	19	20,5	4	5,5	12	7,5	4	35-485-25	35-486-25	35-487-25
35-481-25	35-482-25	35-483-25	25	M 8	40	50	63	19	20,5	4	5,5	12	14	7	35-485-25	35-486-25	35-487-25
35-481-25	35-482-25	35-483-25	25	M10	50	63	80	19	20,5	4	5,5	12	23	11	35-485-25	35-486-25	35-487-25
35-481-32	35-482-32	35-483-32	32	M 8	40	50	63	23	24,5	5	6,5	12	14	7	35-485-32	35-486-32	35-487-32
35-481-32	35-482-32	35-483-32	32	M10	50	63	80	23	24,5	5	6,5	15	23	11	35-485-32	35-486-32	35-487-32
35-481-32	35-482-32	35-483-32	32	M12	63	80	100	23	24,5	5	6,5	15	33	16	35-485-32	35-486-32	35-487-32
35-481-40	35-482-40	35-483-40	40	M 8	50	63	80	26	27,5	6	7,5	15	14	7	35-485-40	35-486-40	35-487-40
35-481-40	35-482-40	35-483-40	40	M10	50	63	80	26	27,5	6	7,5	15	23	11	35-485-40	35-486-40	35-487-40
35-481-40	35-482-40	35-483-40	40	M12	63	80	100	26	27,5	6	7,5	17	33	16	35-485-40	35-486-40	35-487-40
35-481-50	35-482-50	35-483-50	50	M 8	50	63	80	28	29,5	7	8,5	15	14	7	35-485-50	35-486-50	35-487-50
35-481-50	35-482-50	35-483-50	50	M10	50	63	80	28	29,5	7	8,5	15	23	11	35-485-50	35-486-50	35-487-50
35-481-50	35-482-50	35-483-50	50	M12	63	80	100	28	29,5	7	8,5	17	33	16	35-485-50	35-486-50	35-487-50
35-481-50	35-482-50	35-483-50	50	M16	63	80	100	28	29,5	7	8,5	17	40	30	35-485-50	35-486-50	35-487-50
35-481-60	35-482-60	35-483-60	60	M10	50	63	80	36	37,5	8,5	10	17	23	11	35-485-60	35-486-60	35-487-60
35-481-60	35-482-60	35-483-60	60	M12	63	80	100	36	37,5	8,5	10	17	33	16	35-485-60	35-486-60	35-487-60
35-481-60	35-482-60	35-483-60	60	M16	80	100	125	36	37,5	8,5	10	24	62	30	35-485-60	35-486-60	35-487-60
35-481-60	35-482-60	35-483-60	60	M20	98	138	158	36	37,5	8,5	10	24	95	45	35-485-60	35-486-60	35-487-60
35-481-60	35-482-60	35-483-60	60	M24	98	138	158	36	37,5	8,5	10	24	95	45	35-485-60	35-486-60	35-487-60

Exemple de commande

Référence - d₂ - l₁

35-481-25-8-40

 composants.emile-maurin.fr **EMILE MAURIN**
 ELEMENTS STANDARD MECANIQUE