

Pied à rotule technopolymère, à tige filetée inox

35-51

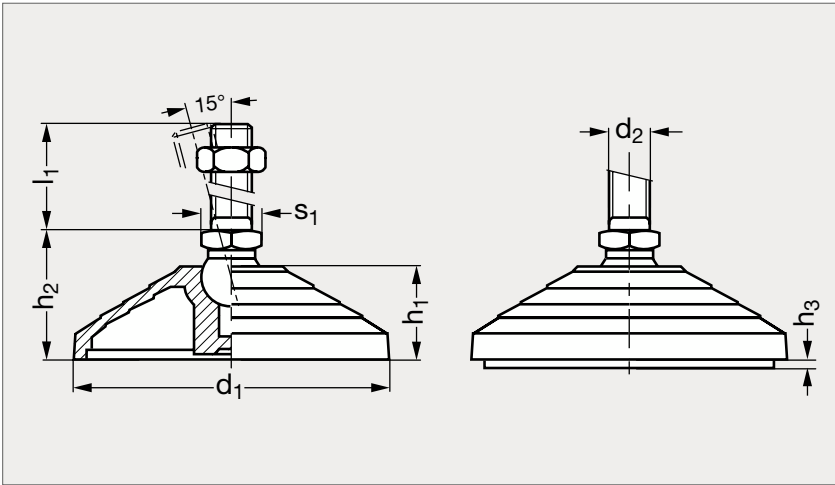

MATIÈRE

- Base en technopolymère noir spécial renforcé de fibres de verre, finition mate.
- Résiste aux solvants, huiles, graisses et autres agents chimiques.
- Tige filetée articulée en inox (AFNOR Z 6 CN 18-09, Werk 1.4301, AISI 304).
- Disque antiglisse en caoutchouc NBR 70 shore A.
- Écrou en inox.

PRODUITS ASSOCIÉS



Insert taraudé 35-60
Page 1004



Insert taraudé 35-61
Page 1006



Insert taraudé 35-62
Page 1005



Insert taraudé 35-63
Page 1007

Pied à rotule technopolymère, à tige filetée inox

35-51

AVEC DISQUE ANTIGLISSE**SANS DISQUE ANTIGLISSE**

Avec écrou	Sans écrou	d ₁	d ₂	h ₁	h ₂	h ₃	l ₁				s ₁	Charge (daN)	Avec écrou	Sans écrou
35-511- 60	35-512- 60	60	M 8	23	32	3	43	68			14	1400	35-515- 60	35-516- 60
35-511- 60	35-512- 60	60	M10	23	32	3	43	68	98		14	1400	35-515- 60	35-516- 60
35-511- 60	35-512- 60	60	M12	23	32	3	43	68	98		14	1400	35-515- 60	35-516- 60
35-511- 60	35-512- 60	60	M16	23	32	3	68	108	148	168	14	1400	35-515- 60	35-516- 60
35-511- 60	35-512- 60	60	M16	23	42	3	58	98	138	158	24	1800	35-515- 60	35-516- 60
35-511- 60	35-512- 60	60	M20	23	42	3	98	138	158	198	24	1800	35-515- 60	35-516- 60
35-511- 60	35-512- 60	60	M24	23	42	3	98	158	198		24	1800	35-515- 60	35-516- 60
35-511- 70	35-512- 70	70	M 8	19	28	3	43	68			14	1400	35-515- 70	35-516- 70
35-511- 70	35-512- 70	70	M10	19	28	3	43	68	98		14	1400	35-515- 70	35-516- 70
35-511- 70	35-512- 70	70	M12	19	28	3	43	68	98		14	1400	35-515- 70	35-516- 70
35-511- 70	35-512- 70	70	M16	19	28	3	68	108	148	168	16	1400	35-515- 70	35-516- 70
35-511- 80	35-512- 80	80	M 8	23	32	3	43	68			14	1600	35-515- 80	35-516- 80
35-511- 80	35-512- 80	80	M10	23	32	3	43	68	98		14	1600	35-515- 80	35-516- 80
35-511- 80	35-512- 80	80	M12	23	32	3	43	68	98		14	1600	35-515- 80	35-516- 80
35-511- 80	35-512- 80	80	M16	23	32	3	68	108	148	168	14	1600	35-515- 80	35-516- 80
35-511- 80	35-512- 80	80	M16	23	42	3	58	98	138	158	24	1800	35-515- 80	35-516- 80
35-511- 80	35-512- 80	80	M20	23	42	3	98	138	158	198	24	1800	35-515- 80	35-516- 80
35-511- 80	35-512- 80	80	M24	23	42	3	98	158	198		24	1800	35-515- 80	35-516- 80
35-511-100	35-512-100	100	M16	23	42	3	58	98	138	158	24	2500	35-515-100	35-516-100
35-511-100	35-512-100	100	M20	23	42	3	98	138	158	198	24	2500	35-515-100	35-516-100
35-511-100	35-512-100	100	M24	23	42	3	98	158	198		24	2500	35-515-100	35-516-100
35-511-125	35-512-125	125	M16	45	66	3	58	98	138	158	24	2800	35-515-125	35-516-125
35-511-125	35-512-125	125	M20	45	66	3	98	138	158	198	24	2800	35-515-125	35-516-125
35-511-125	35-512-125	125	M24	45	66	3	98	158	198		24	2800	35-515-125	35-516-125

Exemple
de commandeRéférence - d₂ - l₁

35-511-60-8-43

 composants.emile-maurin.fr

 ELEMENTS STANDARD MECANIQUE