

Charnière asymétrique ou large, nœud à plat, acier ou inox

37-104

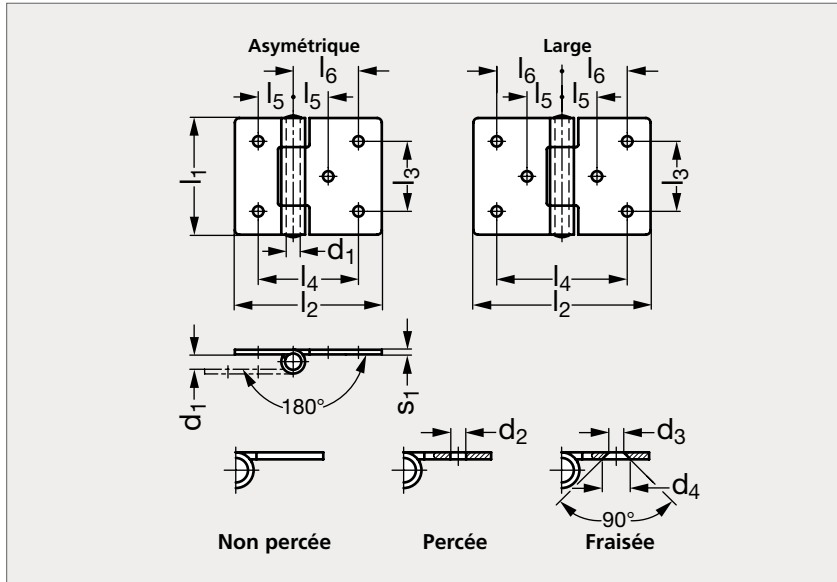

Acier, percée



Acier, fraisée



Inox non percée



Inox, fraisée

MATIÈRE

- Acier zingué, passivé bleu ou inox A2 (AFNOR Z 6 CN 18-09, Werk 1.4301, AISI 304).
- Axe en inox A2 (AFNOR Z 6 CN 18-09, Werk 1.4301, AISI 304), riveté.

PRODUITS ASSOCIÉS

Vis tête fraisée 31-153
Page 1336Joint d'étanchéité 19-180
Page 642Joint de protection 19-184
Page 644Verrous et loquets
Page 570

ACIER

ACIER														INOX		
Percée	Fraisée	l_1	l_2 Asym.	l_2 Large	l_3	l_4	l_5	l_6	d_1	d_2	d_3	d_4	h_1	Non percée	Percée	Fraisée
37-1041-30	37-1042-30	30	45	60	18	3348	9	24	3	3,2	4	6,4	1,5	37-1045-30	37-1046-30	37-1047-30
37-1041-40	37-1042-40	40	60	80	25	4565	12,5	32,5	4	4,2	5	8,3	2	37-1045-40	37-1046-40	37-1047-40
37-1041-50	37-1042-50	50	75	100	30	5580	15	40	6	5,2	5	8,3	2	37-1045-50	37-1046-50	37-1047-50
37-1041-60	37-1042-60	60	90	120	36	6696	18	48	6	5,2	5	8,3	2	37-1045-60	37-1046-60	37-1047-60

Exemple
de commandeRéférence - l_2

37-1041-30-45

composants.emile-maurin.fr

EMILE MAURIN
ELEMENTS STANDARD MECANIQUE