

# Charnière à friction réglable zamac

37-110

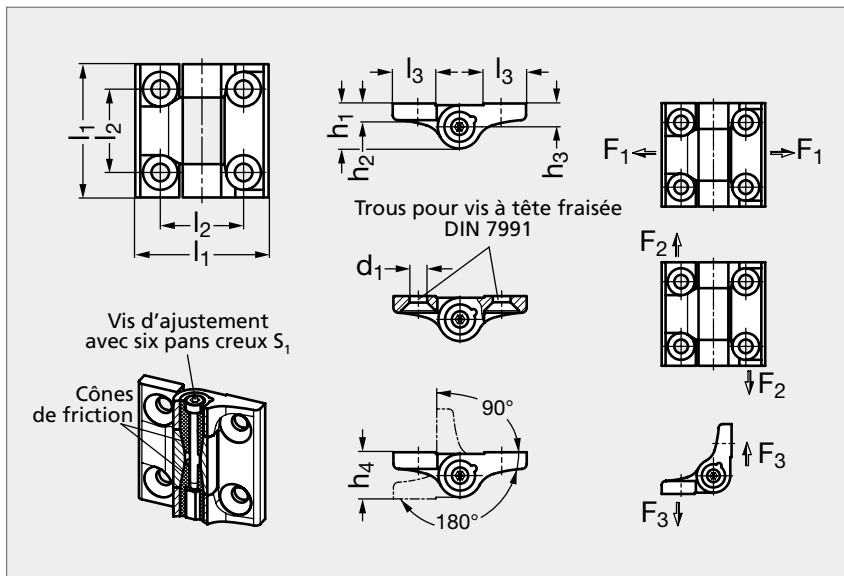

Zamac gris



Zamac noir

## MATIÈRE

- Zamac pelliculé noir (RAL 9005) ou gris (RAL 9006).
- Cônes de friction en plastique (Polyacétal POM).
- Vis d'ajustement et écrou en acier zingué, passivé bleu.

## PRODUITS ASSOCIÉS

Vis tête fraisée 31-153  
Page 1336Joint d'étanchéité 19-180  
Page 642Joint de protection 19-184  
Page 644Verrous et loquets  
Page 570

Noir	$l_1$	$l_2$	$l_3$	$d_1$	$h_1$	$h_2$	$h_3$	$h_4$	$s_1$	Couple max vis d'ajustement (Nm)	Couple de friction (Nm)	$F_1$ (N)	$F_2$ (N)	$F_3$ (N)	Gris
37-1101-40	40	25	13	5,3	13,5	5	7	14	2,5	1	4	2500	1200	1500	37-1102-40
37-1101-50	50	30	16,5	6,5	15,5	6	8	16	3	1,4	6	3200	1600	2000	37-1102-50
37-1101-60	60	36	20	8,3	18,5	7,5	9,5	19	4	1,7	8	4500	2000	2400	37-1102-60

Exemple  
de commande

Référence

37-1101-40