

# Charnière plate zamac, inox ou aluminium

37-12

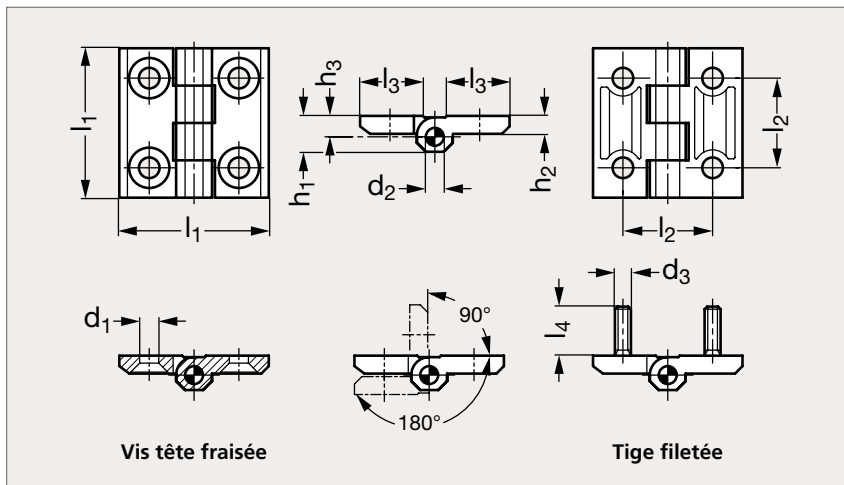

Aluminium



Zamac noir



Inox 316

## MATIÈRE

- Zamac pelliculé noir (RAL 9005) ou gris argenté (RAL 9006) ou chromé ou inox (AFNOR Z 6 CN 18-10 M, Werk 1.4308, AISI CF-8) ou inox (AFNOR Z 6 CND 17-11, Werk 1.4401, AISI 316) ou aluminium anodisé, couleur naturelle.
- Axe en inox (AFNOR Z 8 CNF 18-09, Werk 1.4305, AISI 303) pour les modèles en zamac ou en inox (AFNOR Z 6 CNDT 17-12, Werk 1.4571, AISI 316 Ti) pour les modèles en aluminium et en inox.

## PRODUITS ASSOCIÉS

Vis tête fraisée 31-153  
Page 1336Joint d'étanchéité 19-180  
Page 642Joint de protection 19-184  
Page 644Verrous et loquets  
Page 570

Zamac noir	Zamac gris	Zamac chromé	Aluminium	$l_1$	$l_2$	$l_3$	$d_1$	$d_2$	$h_1$	$h_2$	$h_3$	Inox CF-8	Inox 316
37-120-30	37-121-30	37-124-30	37-128-30	30	18	10,7	4,3	3	7,5	4	4,5	37-125-30	37-127-30
37-120-40	37-121-40	37-124-40	37-128-40	40	25	16	5,3	4	9	5	5,5	37-125-40	37-127-40
37-120-50	37-121-50	37-124-50	37-128-50	50	30	21	6,4	6	11,5	6	6,5	37-125-50	37-127-50
37-120-60	37-121-60	37-124-60	37-128-60	60	36	26	8,3	8	15	8	8,5	37-125-60	37-127-60

## Référence

37-120-30

Exemple  
de commande