

Charnière non percée, renforcée, nœud à plat, inox

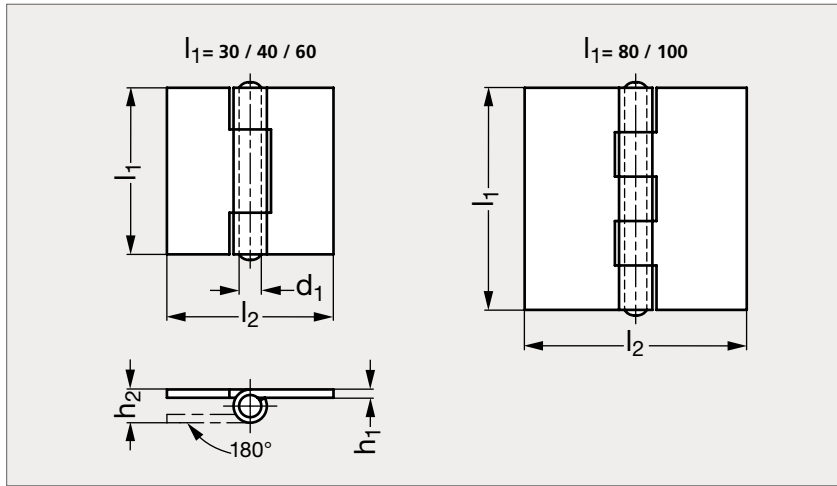

MATIÈRE

- Inox A2 (AFNOR Z 6 CN 18-09, Werk 1.4301, AISI 304).
- Axe riveté.

	l_1	l_2		d_1	h_1	h_2
37-1720-30	30	60	80	6	3	12
37-1720-40	40	60	80	6	3	12
37-1720-60	60	60		6	3	12
37-1720-80	80	80		6	3	12
37-1720-100	100	100		6	3	12

Exemple
de commande

Référence - l_2

37-1720-30-60

composants.emile-maurin.fr

EMILE MAURIN
ELEMENTS STANDARD MECANIQUE